



DLS SERIES WATER-AIR COOLED DUMMY LOAD POWER METER

DLS 5kW

WATER-AIR COOLED DUMMY LOAD POWER METER



Power Rating	5kW
Frequency Range	DC-880MHz
Impedance	50 Ω
VSWR	≤1.10:1
Input Connectors	15/8" EIA Flange or 15/8" Rigid line
Cooled	Water-Air
Power Meters	Digital display
Interface	RS-485
Nominal Dimensions	790×510×610(mm)
Nominal Weight	67(kg)

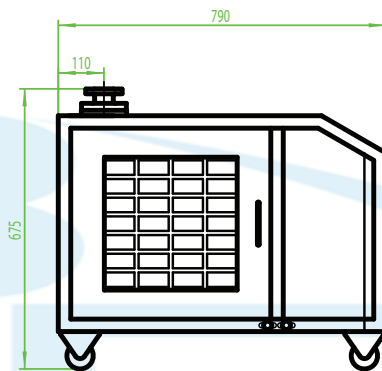
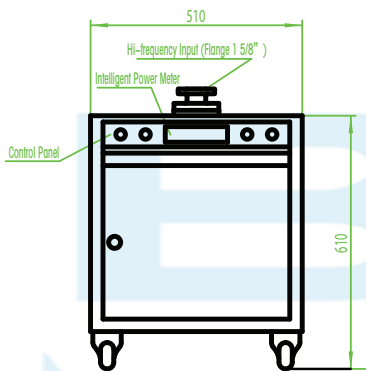

External drawing of the flange 1 5/8"

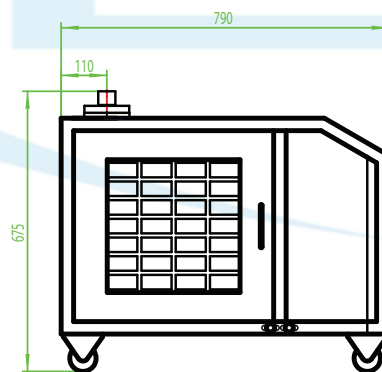
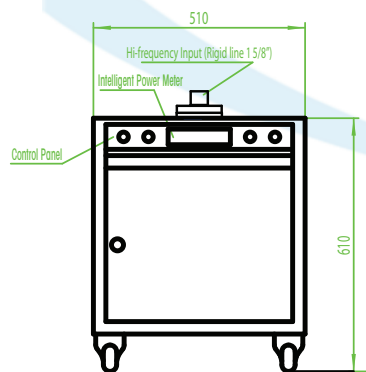

External drawing of the Rigid line 1 5/8"



Tel: +8610 80119366
Fax: +8610 69705030
E-mail: BED@RF-BED.com